

RapidNetRail Cabinet Solution: 84"H X 24"W X 36"D  
PART# FRN84ED-3HTR

**RAPIDNETRAIL™ M6 CAGE-NUT, 47U**  
(2) PAIR, 19" EIA-310-D COMPLIANT

**PATENT PENDING**

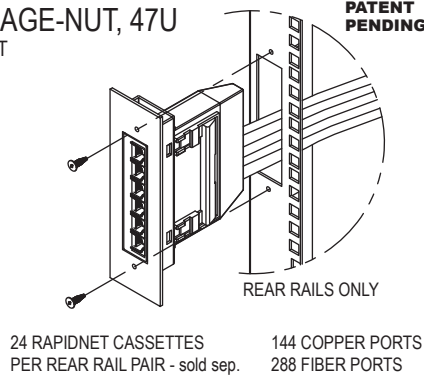
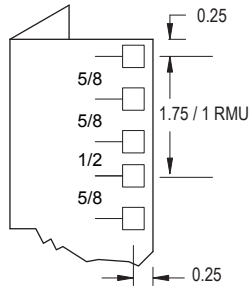

**TOP VIEW**

OPTIONAL TOP PANEL  
PART# TE2436V-3HTR

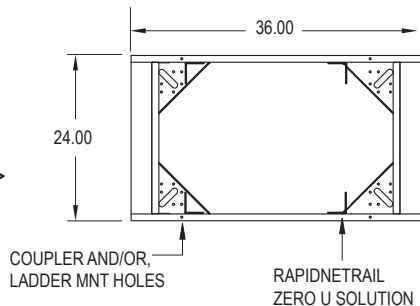
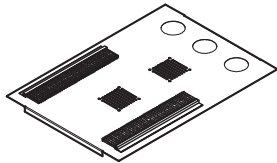

**BOTTOM VIEW**

FLOOR MNT DIMS: 17.25 x 25.25  
(4) FLOOR LEVELERS INCLD.



OPTIONS:  
CASTER KIT: PART# AFCYO  
HD FLR LEVELERS: HD92203

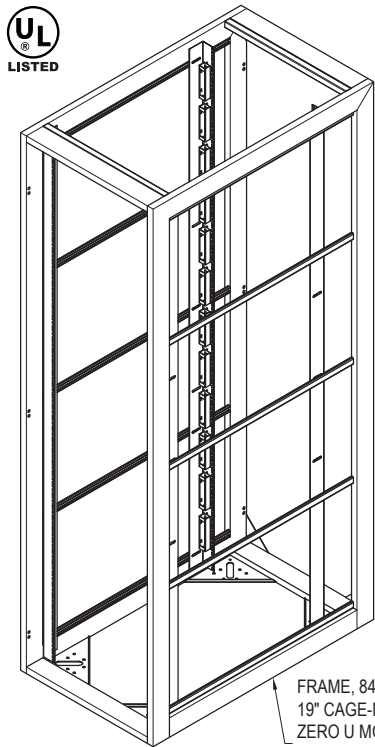
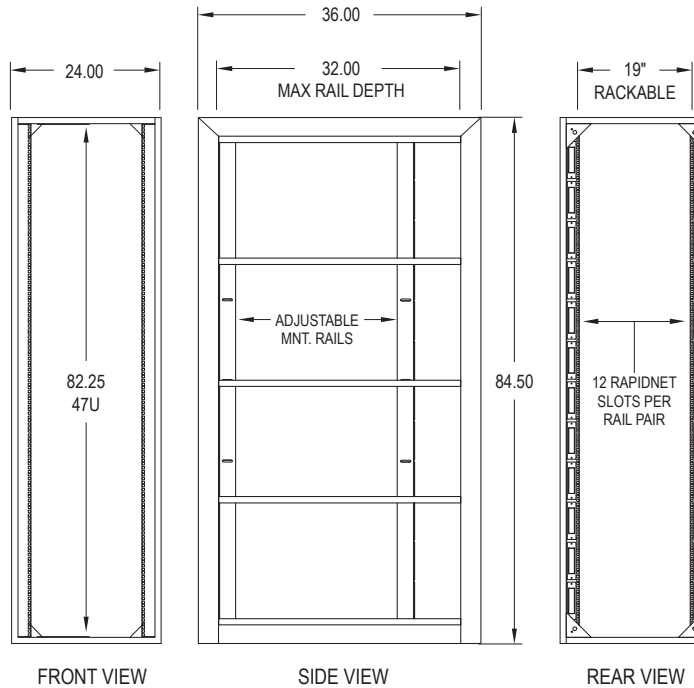
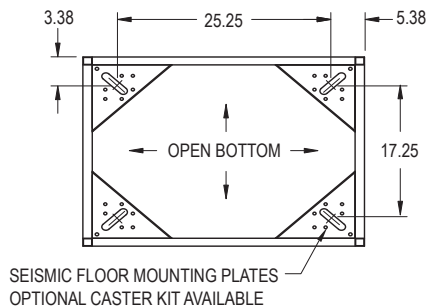

**DIMENSIONS**

EXTREME FRAME  
1 x 3 TUBULAR STEEL  
HEIGHT: 84.50  
WIDTH: 24.00  
DEPTH: 36.00

**WT CAPACITY**

3000 LBS. STATIC CAP.  
2000 LBS. ROLLING CAP.

**RATING**

SEISMIC ZONE 4

**MOUNTING RAIL**

47 RMU, L-RACK ANGLES  
M6 CAGE-NUT, SQ HOLE  
EIA SPACING, 5/8 x 5/8 x 1/2  
19" RACKABLE  
ADJUSTABLE, MAX 32.00 DEPTH  
R. RAIL PAIR: RAPIDNET READY  
12 CASSETTES/RAIL, 24/PAIR

**SIDE PANEL, NONE**

OPTIONAL SOLID SIDE PANEL (1x)  
PART# SE8436S-3

**DOORS, NONE**

OPTIONAL DOOR W/ LOCK  
MESH: PART# DE8424B-3  
V.PLEX: PART# DE8424V-3

**TOP, NONE**

OPTIONAL VENTED TOP PANEL)  
PART# TE2436V-3HTR

**COLOR**

BLACK, TEXTURED  
EPOXY POWDER-COAT

**CLASSIFICATION**

SEISMIC ZONE 4  
UL LISTED  
19" EIA-310-D COMPLIANT  
ROHS COMPLAINT

All information has been expressed with the highest degree of accuracy, however DAMAC does not accept liability in the event there are printed errors or omissions. All DAMAC trademarks are property of Damac Products, Inc. Other trademarks are property of their respective owners. Printed information and specifications are subject to change without notice.  
©2008 DAMAC Products, Inc. All Rights Reserved



14489 INDUSTRY CIRCLE  
LA MIRADA, CA 90638  
TEL: 888.949.2289  
WWW.DAMAC.COM

ALL INFORMATION ARE PROPRIETARY DATA OF DAMAC PRODUCTS INC. ANY REPRODUCTION/USE IN ANY FORM MUST HAVE PRIOR WRITTEN AGREEMENT W/ DAMAC.  
TOLERANCE: .XXX±0.10 .XX±0.30 .X±0.60 (DEG)±.5  
ALL DIM. ARE IN INCHES UNLESS OTHERWISE SPECIFIED

TITLE: CABINET, RAPIDNETRAIL™  
84.00 x 24.00 x 36.00  
19" RACKABLE

PART NO.  
FRN84ED-3HTR  
ENG: AP 06.02.2008

CHECKED BY:  
CR  
SHEET: 1/1

MATERIAL: N/A  
FINISH: EPOXY POWDER-COAT, BLACK  
MAX BEND R=.030, RELIEF=.060 AIR.  
UNLESS OTHERWISE SPECIFIED

