

TANDEM RACK SERIES
R4S19084CNB-3MU W/CAGE-NUT CHANNELS

REVISIONS			
REV	ECO	DATE	DESCRIPTION
A	--	05.08.2008	CHANGE HARDWARE FROM 12-24 SCREWS TO M6 SCREWS.

DIMENSIONS

TANDEM RACK
 HEIGHT 84.00"
 WIDTH 20.25"
 DEPTH 29.00"

RAIL TYPE

STEEL UPRIGHTS
 CAGE-NUT
 19" RACKABLE

SPECIFICATIONS

- * STANDARD EIA HOLE PATTERN: $\frac{5}{8}$ " $\frac{5}{8}$ " $\frac{1}{2}$ "
- * TOP AND BASE ANGLES CONSTRUCTED OF 6061-T6 ALUMINUM
- * UPRIGHTS CONSTRUCTED OF STEEL (14GA)
- * DURABLE BLACK POWDER COATED FINISH
- * ASSEMBLY HARDWARE INCLUDED (BLACK)
- * M6 CAGE-NUT W/M6 SCREWS, BLACK (40pcs)
- * PANEL MOUNTING HOLE CENTERS, 19" RACK: 18.31"
- * MINIMUM INSIDE DIMENSION UPRIGHT, 19" RACK: 17.75"
- * PROVIDES 45 USABLE RACK UNITS
- * LOAD CAPACITY: 2000 LBS.
- * RMU MARKINGS

TOP VIEW

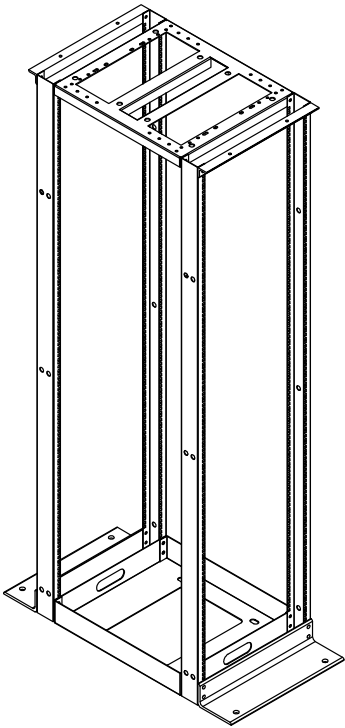
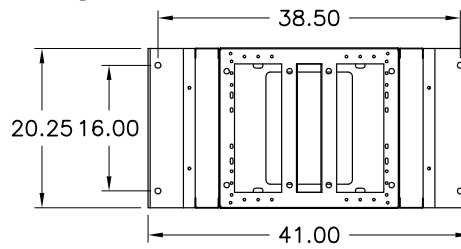

ISOMETRIC VIEW

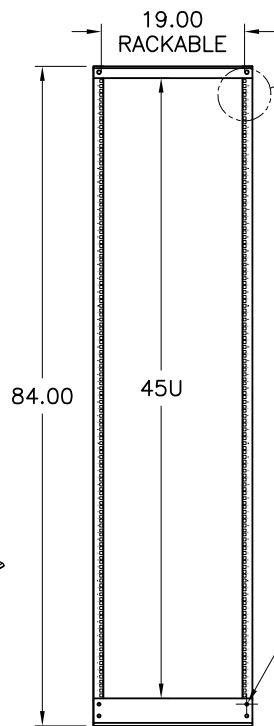

FRONT VIEW

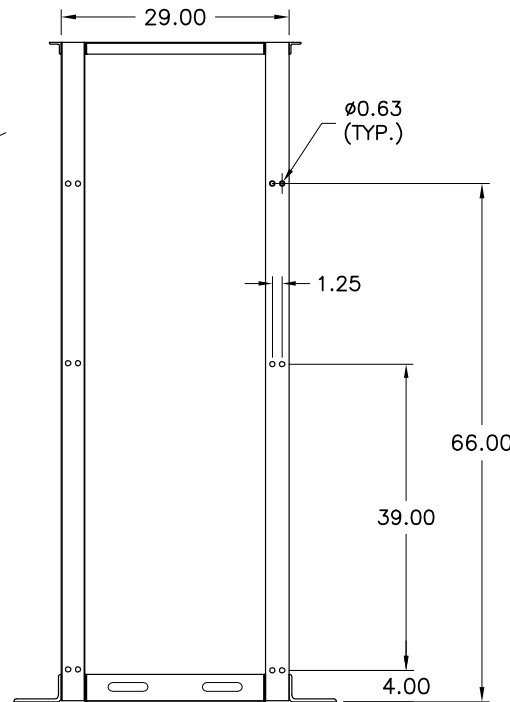
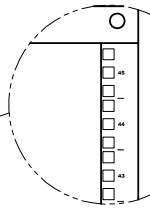

SIDE VIEW

DAMAC PRODUCTS INC. LA MIRADA, CA 90638	ALL INFORMATION ARE PROPRIETARY DATA OF DAMAC PRODUCTS INC. ANY REPRODUCTION/USE IN ANY FORM MUST HAVE PRIOR WRITING AGREEMENT W/ DAMAC. TOLERANCE .0004-.010 .004-.030 .04-.060 (DEG) \pm .5 ALL DIM. ARE IN INCHES UNLESS OTHERWISE SPECIFIED	TITLE: RACK, TANDEM, STEEL 84"H x 19" RACK x 29"D 19" RACKABLE, CAGE-NUT	PART NO. R4S19084CNB-3MU	CHECKED BY: CR	SCALE: N/A	MATERIAL: N/A FINISH: POWDER-COATED BLACK MAX BEND R=.030, RELIEF=.060 A/R. UNLESS OTHERWISE SPECIFIED
			DRAWN BY: AP	DATE: 02.20.2008	SHEET: 1 OF 1	