

**TANDEM RACK SERIES**  
**R4S19084CND-3MU W/CAGE-NUT CHANNELS**

REVISIONS			
REV	ECO	DATE	DESCRIPTION
A	--	05.08.2008	CHANGE HARDWARE FROM 12-24 SCREWS TO M6 SCREWS.

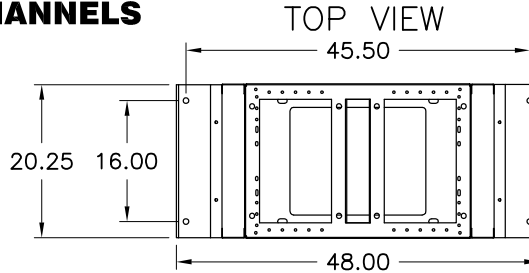

**DIMENSIONS**

**TANDEM RACK**  
 HEIGHT 84.00"  
 WIDTH 20.25"  
 DEPTH 36.00"

**RAIL TYPE**

**STEEL UPRIGHTS**  
 CAGE-NUT  
 19" RACKABLE

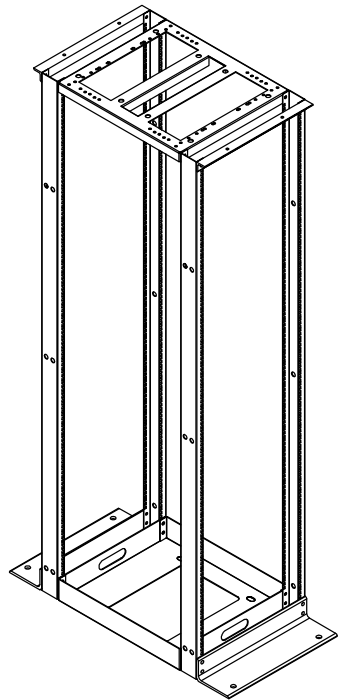

ISOMETRIC VIEW

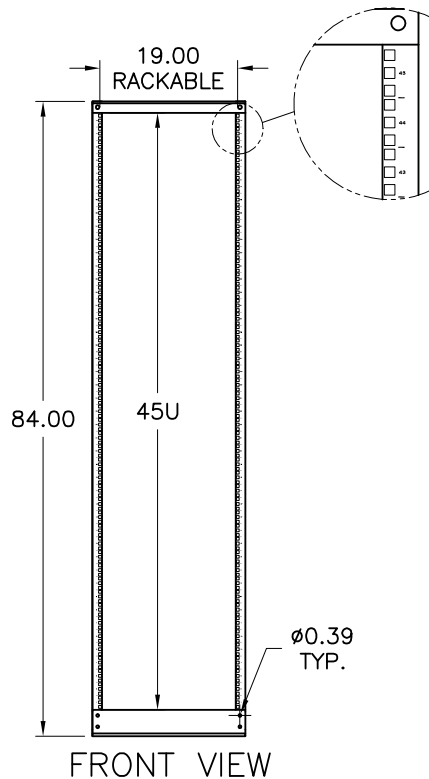

FRONT VIEW

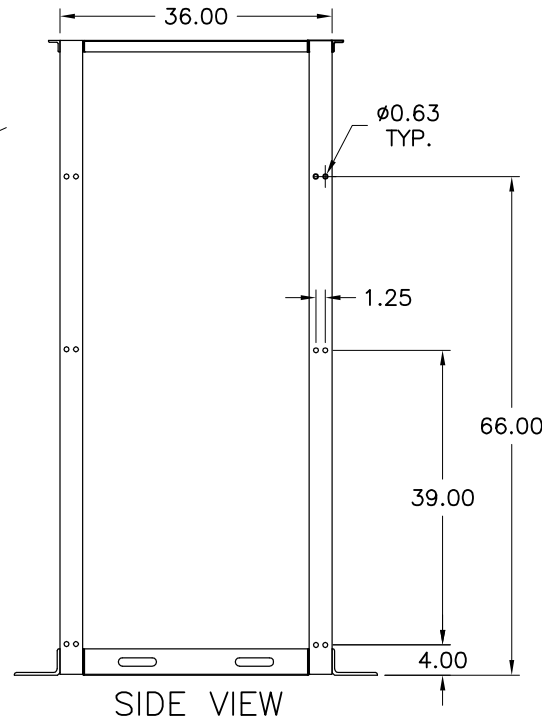

SIDE VIEW

**SPECIFICATIONS**

- \* STANDARD EIA HOLE PATTERN:  $\frac{5}{8}$ "  $\frac{5}{8}$ "  $\frac{1}{2}$ "
- \* TOP AND BASE ANGLES CONSTRUCTED OF 6061-T6 ALUMINUM
- \* UPRIGHTS CONSTRUCTED OF STEEL (14GA)
- \* DURABLE BLACK POWDER COATED FINISH
- \* ASSEMBLY HARDWARE INCLUDED (BLACK)
- \* M6 CAGE-NUT W/SCREWS, BLACK (40pcs)
- \* PANEL MOUNTING HOLE CENTERS, 19" RACK: 18.31"
- \* MINIMUM INSIDE DIMENSION UPRIGHT, 19" RACK: 17.75"
- \* PROVIDES 45 USABLE RACK UNITS
- \* LOAD CAPACITY: 2000 LBS.
- \* RMU MARKINGS

<b>DAMAC</b> PRODUCTS INC. LA MIRADA, CA 90638	ALL INFORMATION ARE PROPRIETARY DATA OF DAMAC PRODUCTS INC. ANY REPRODUCTION/USE IN ANY FORM MUST HAVE PRIOR WRITING AGREEMENT W/ DAMAC. TOLERANCE .XXX±.010 .XX±.030 .X±.050 (DEC)±.5 ALL DIM. ARE IN INCHES UNLESS OTHERWISE SPECIFIED	TITLE:	RACK, TANDEM, STEEL	PART NO.	R4S19084CND-3MU	CHECKED BY:	CR	SCALE:	N/A	MATERIAL:	N/A
		84"H x 19"RACK x 36"D	19"RACKABLE, CAGE-NUT	DRAWN BY:	AP	DATE:	02.20.2008	SHEET:	1 OF 1	REV:	A